

5801 STD

PRINT COLOR: BLACK
 TYPE 4385801 STD DYNAR
 CLB THPR 8UF/400V
 1PH 230V 50Hz 2.0A HP1/3
 RPM: 1400 DATE

WRES CAT No:	1615801		
DESCRIPTION	COLOR	LENGTH	FASTON COVER
	WHITE/BROWN	900+50	FASTON 250+ COVER
	RED/BLACK/BLE	130+50	FASTON 250+ COVER
	BLUE/ORANGE	950+50	STRIP 6 MM
	YELLOW/GREEN	850-50	
	BLACK	120-20	

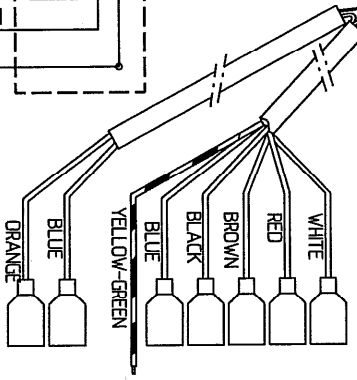
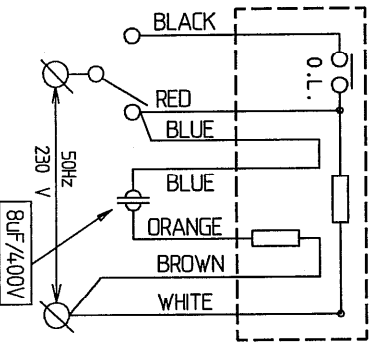
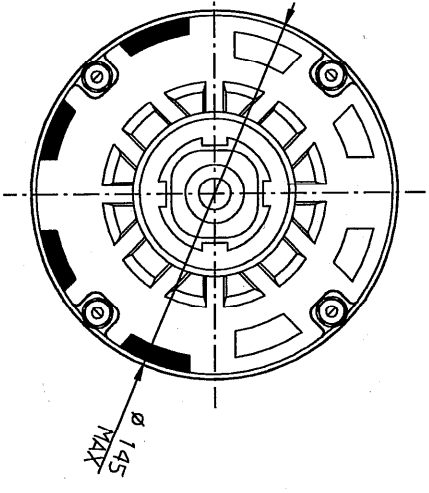
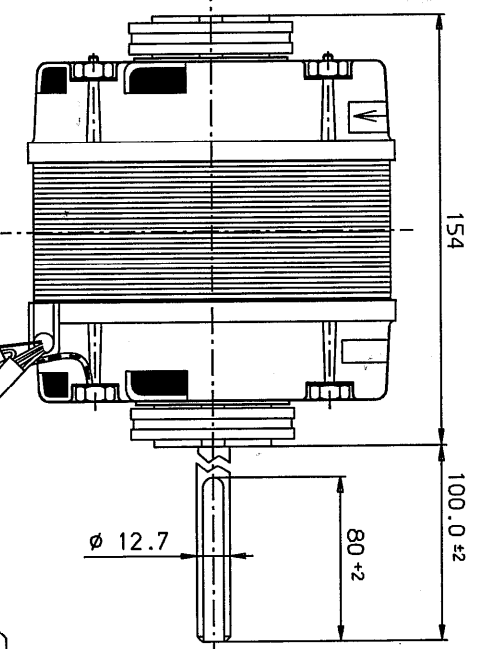
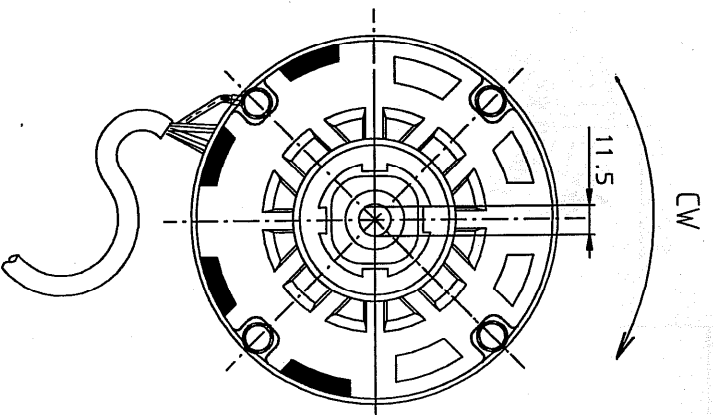

DRWG	4616	Motor label	STD
Drawn	EL	CatNo:	1315801
Approved		Motor type	4385801
Scale	1:3	Customer	AMICOR
Gen. Tolerance	±0.5	File:	E-GRV438-5801\ASSY
		Vt.	5801
		PRINT:	19/5/02